

CS 1550: Chapter 1

Jonathan Misurda
jmisurda@cs.pitt.edu
<http://www.cs.pitt.edu/~jmisurda/>

Operating Systems

- Manage Resources
- Abstract Details

Manage Resources

- CPU Time
- Memory
- I/O Devices
 - Disks/Filesystems
- Security

Abstract Details

- Exclusive access to the CPU(s)
- Huge amounts of dedicated RAM
- Exclusive access to I/O devices
- Transparent security

In short, **SHARING**

Varieties of OS

- Mainframe OS
- Server OS
- Parallel Computer OS
- Personal Computer OS
- Real-Time OS
 - Hard real-time
 - Soft real-time
- Embedded OS
- Smart Card OS

Ye Olde Computer

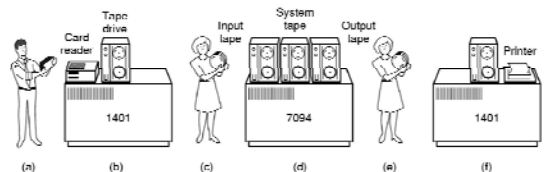

Ye Olde Program

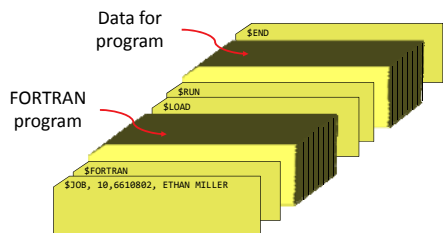

Punchcard

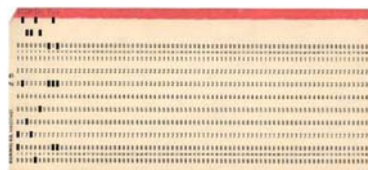

Why Study History?

Ontogeny Recapitulates Phylogeny

Development of the species is mimicked by the gestation of an individual

Or:

What's old will be new again



Multiprogramming

Multiprogramming

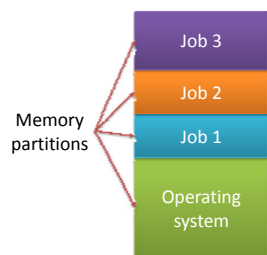
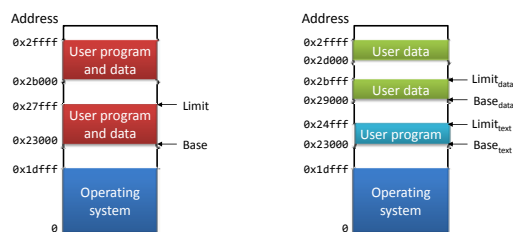
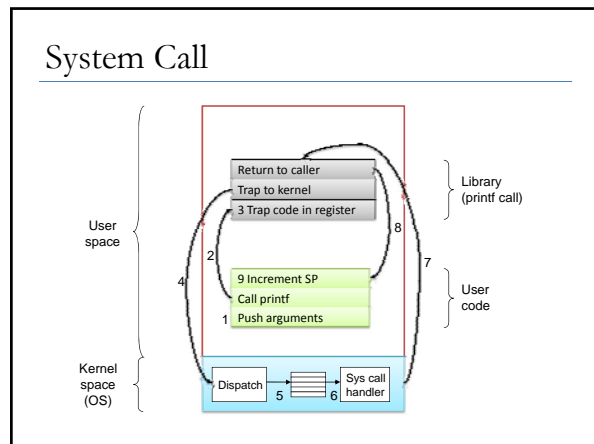
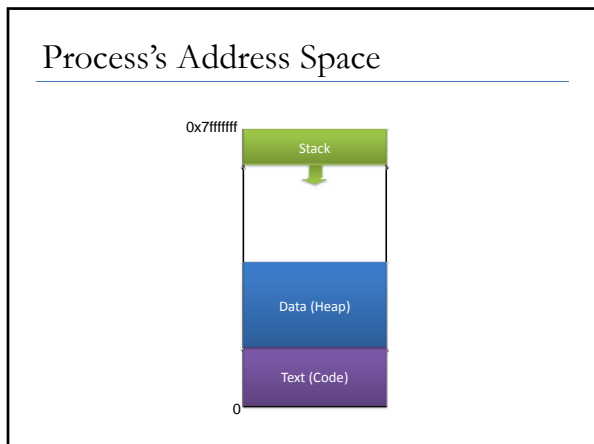

Image Protection





Context Switch

Switching from one running process to another

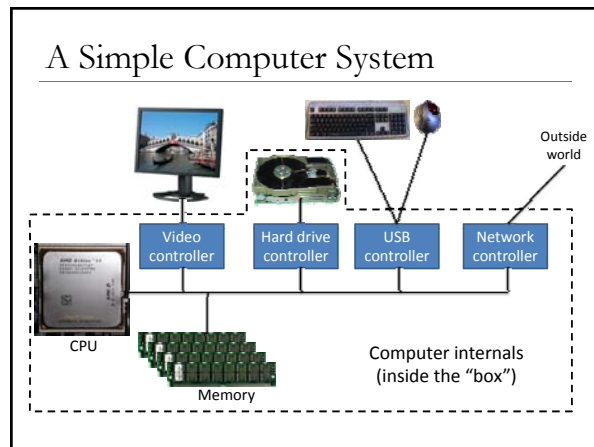

- ### Protect and Share
- CPU time
 - Preemption
 - Memory
 - Address Spaces/Virtual Memory
 - I/O
 - Spool
 - Simultaneous Peripheral Operation On Line
 - Security

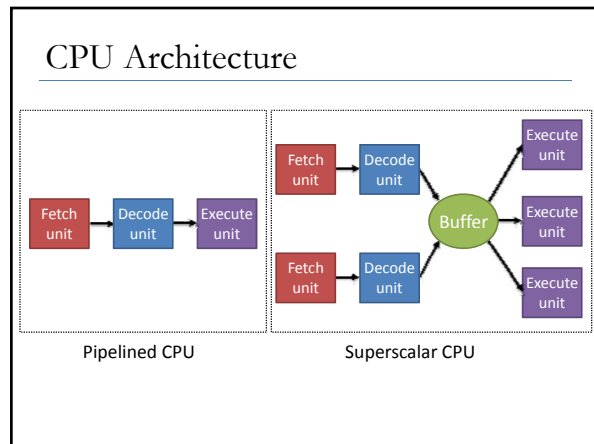

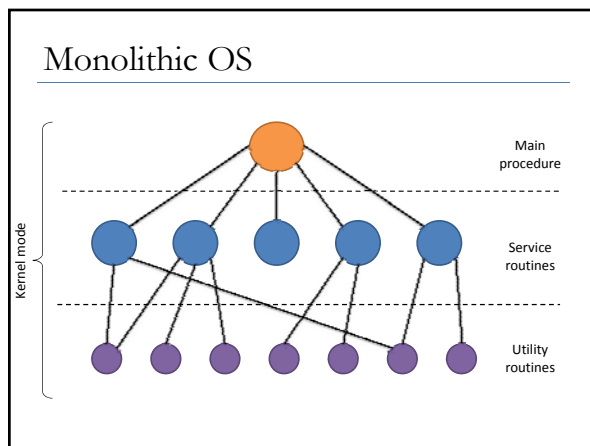
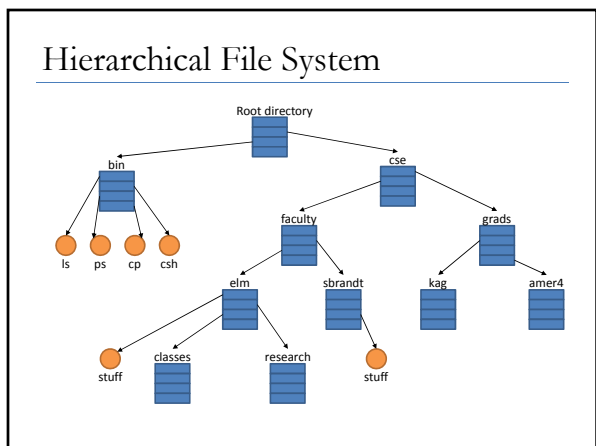
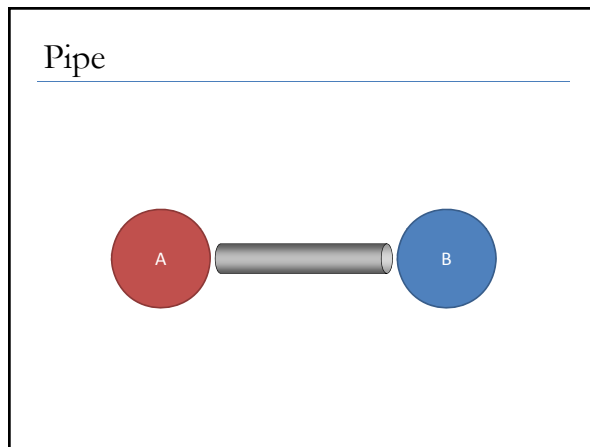
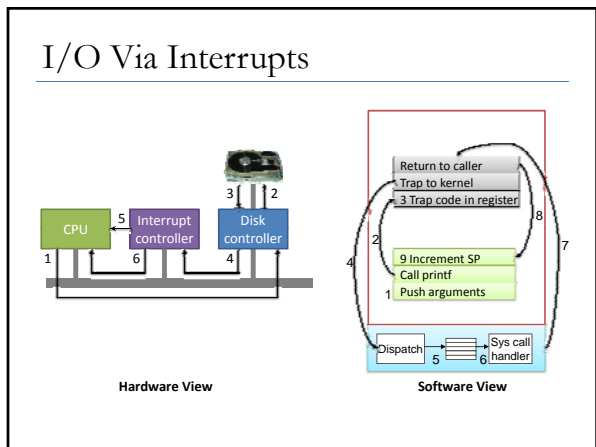
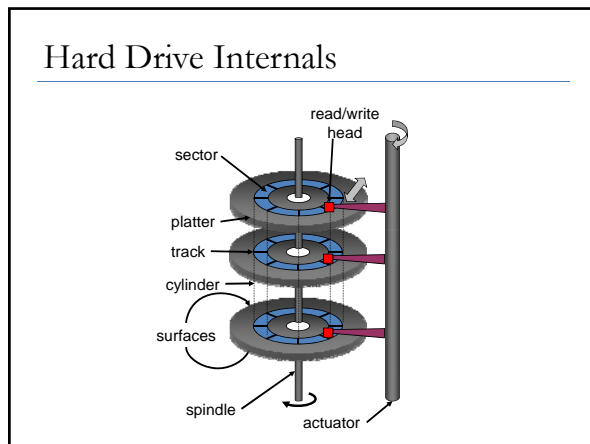
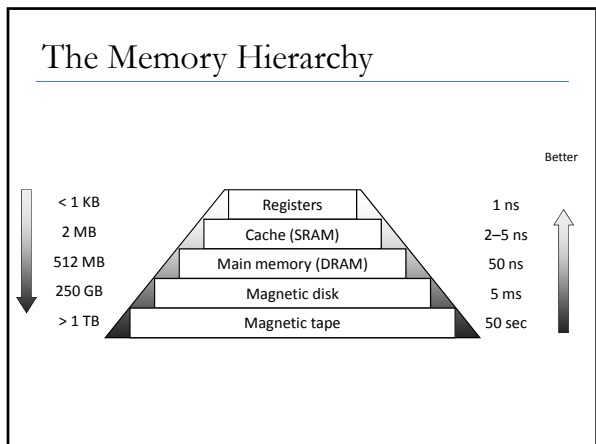

Microkernel

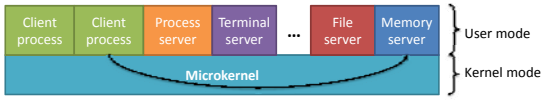

Virtual Machines

